

International Meteor Conference

Sep 19th - 22nd, 2024
Kutná Hora, czech Republic

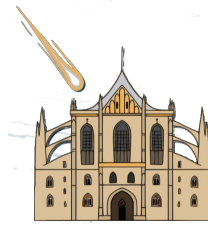

First Meteor Observations with SPADE

Adrien Manuel Mascarenhas, Lucas Maurice,
Antonio Martínez Picar & Christophe Marqué



Royal Observatory
of Belgium



Solar-Terrestrial
Center of Excellence

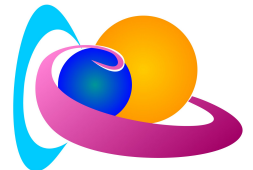

SPADE description

Array description

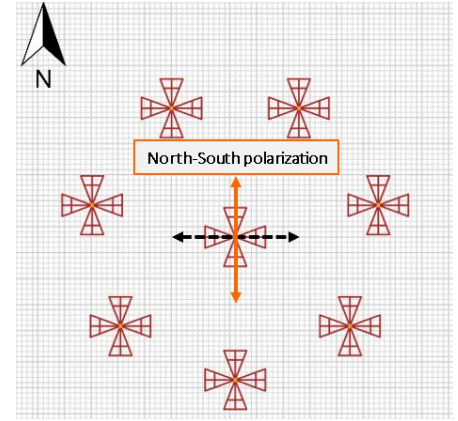

SPADE Mechanism

SPADE Configuration

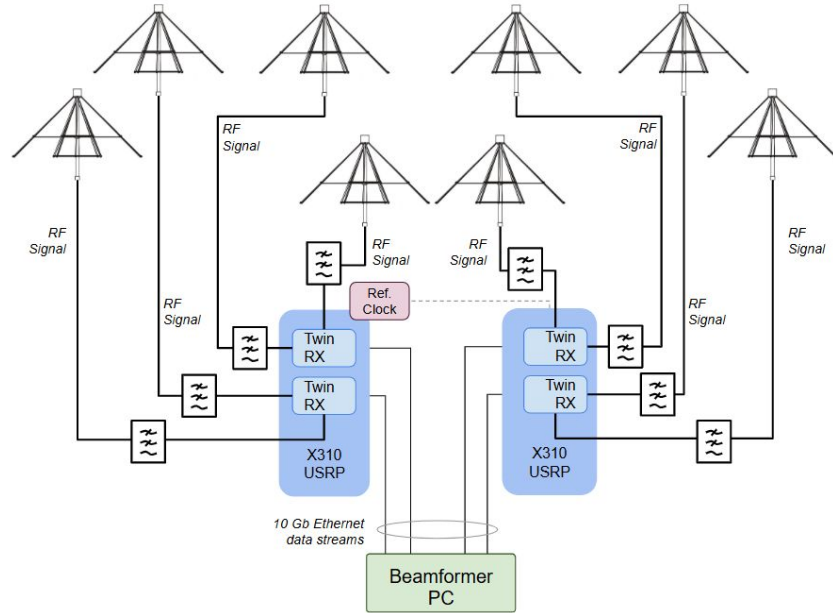

Beamforming technique

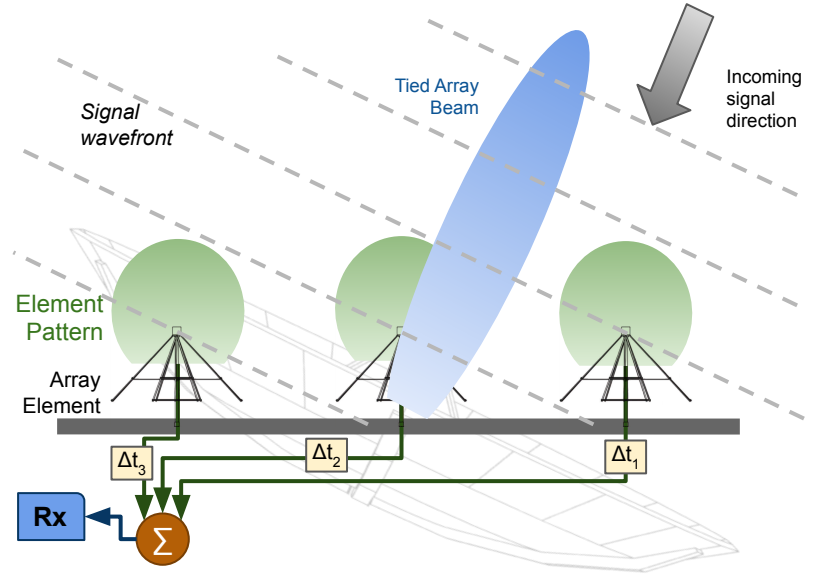

Conducting Meteor Observations with SPADE

Forward scatter principle

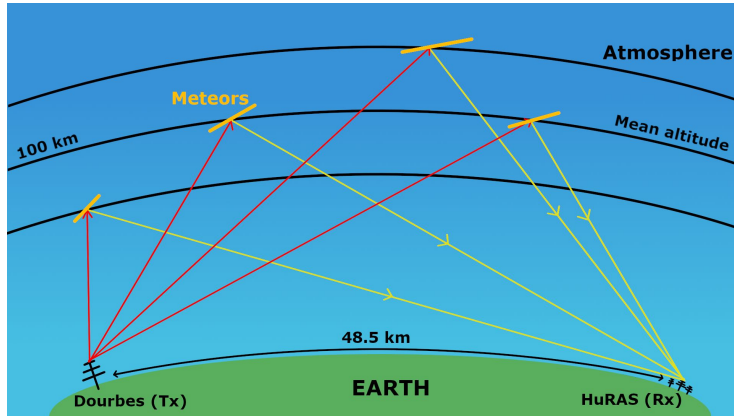

BRAMS - Transmitter [$\sim 50\text{MHz}$]



SPADE - Receiver [20-80MHz]

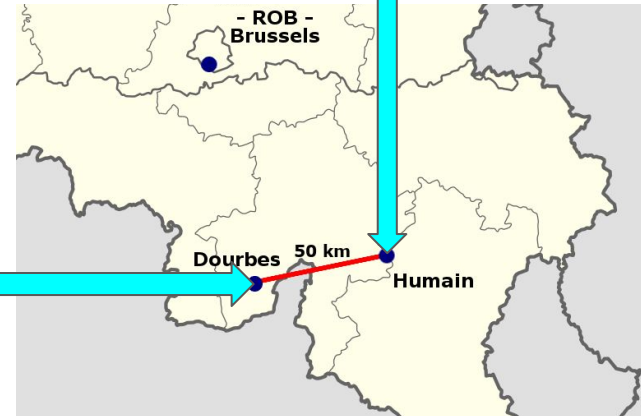

SPADE sampling synchronisation

Ettus USRP X300



Local Oscillator distribution

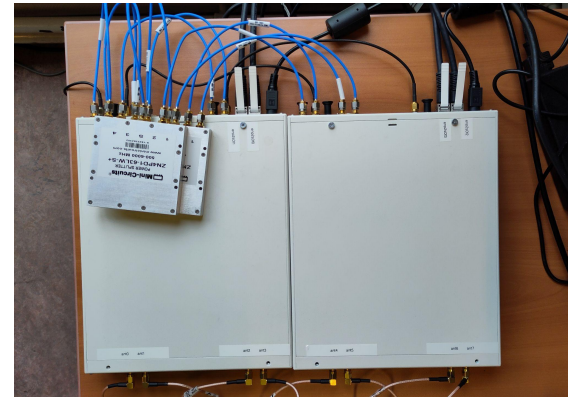

SPADE phase synchronisation

Phases synchronised

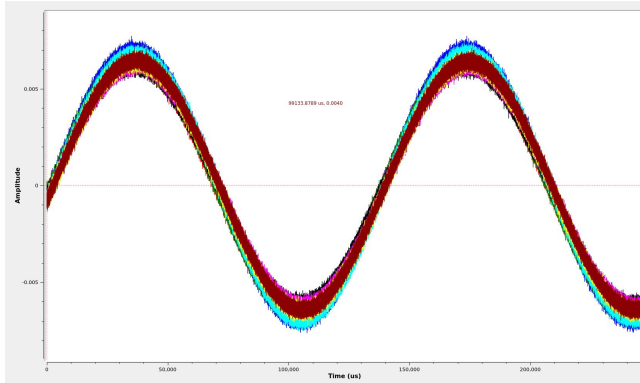

In that configuration :

- 3dB beamwidth = 20°
- max gain = 21 dBi

SPADE pattern

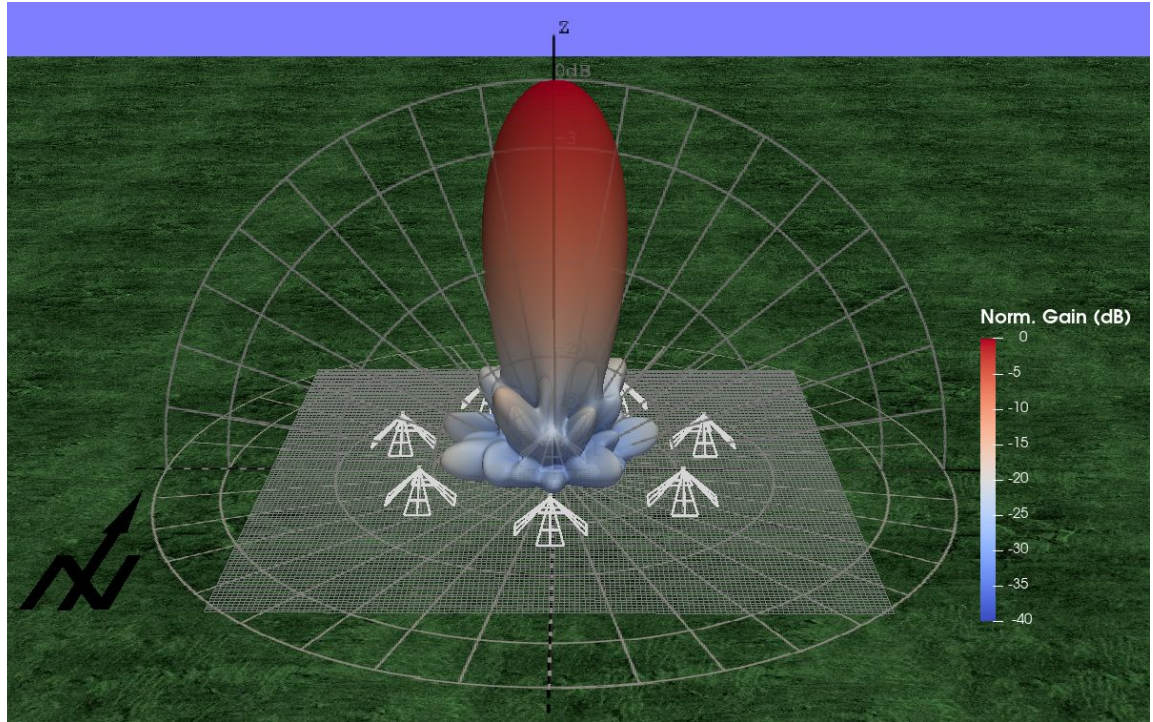

Observations

GNU-Radio interfaces

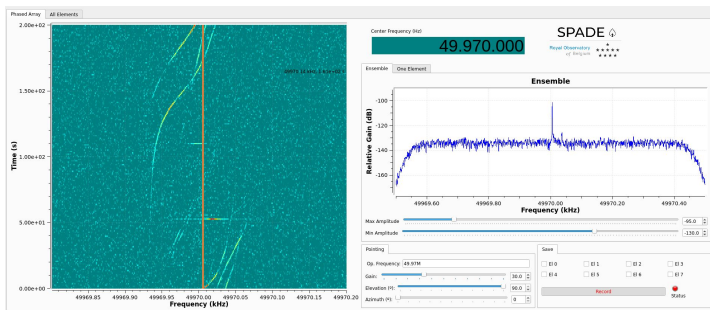
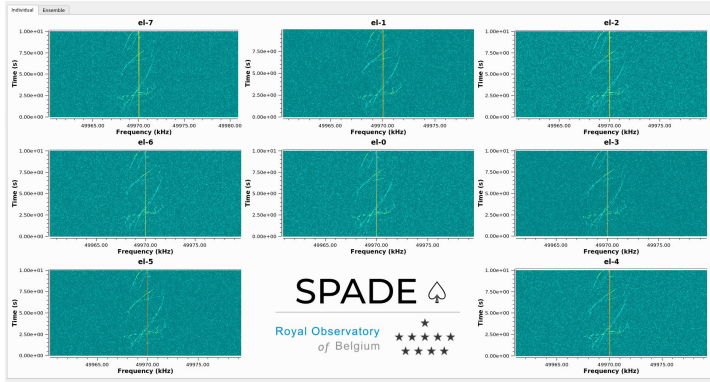

Data from SPADE in spectrograms

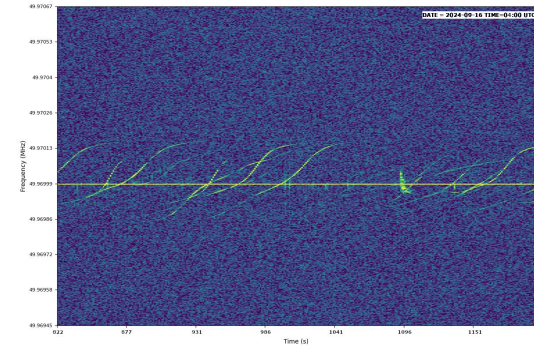
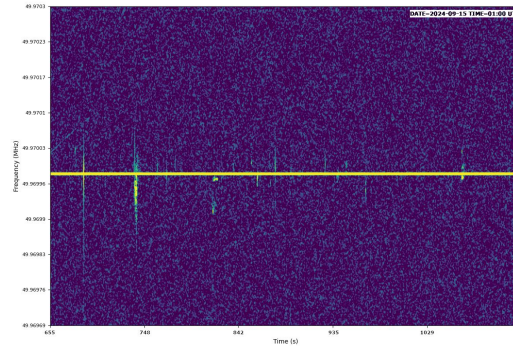
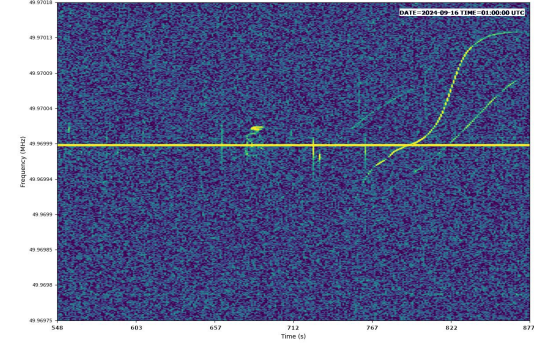
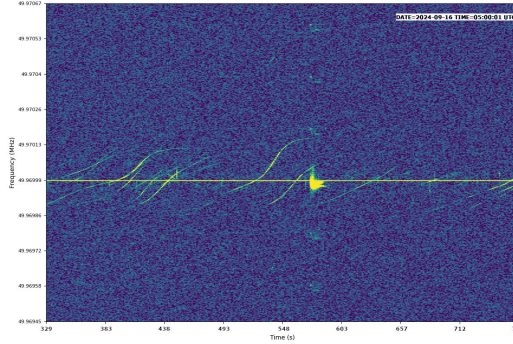

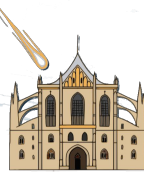

Thank you for listening
Do you have any questions ?

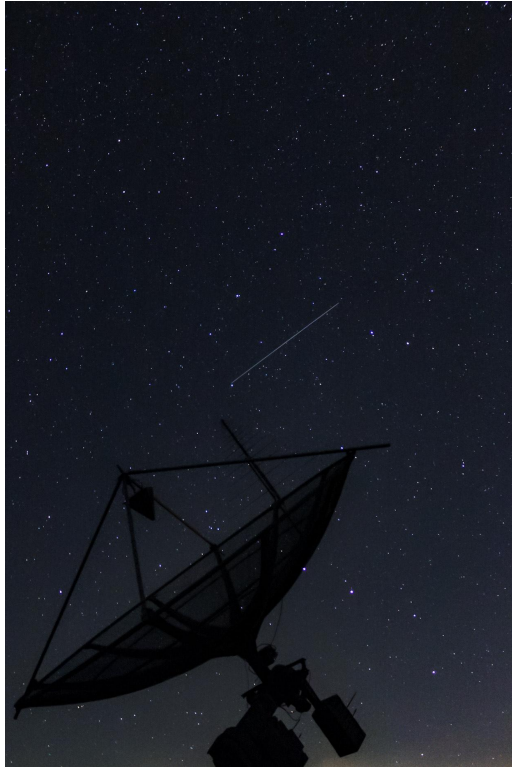

a.manuel-mascarenhas@elisa-aerospace.fr
antonio.martinez@observatory.be

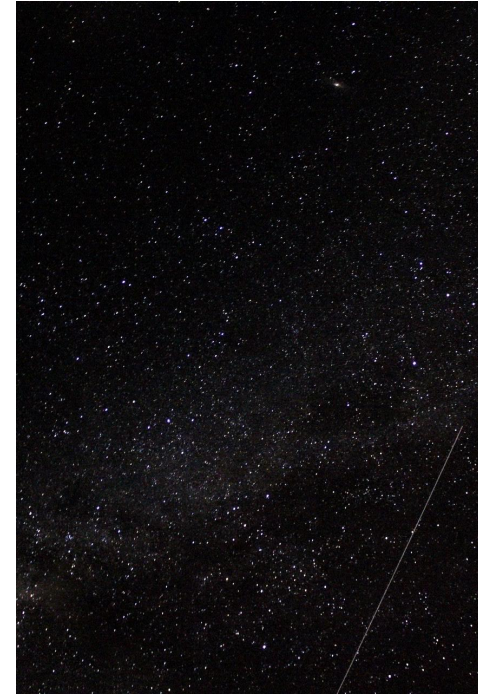

Royal Observatory
of Belgium



Solar-Terrestrial
Center of Excellence

